

USB-2404-UI

USB-based Universal Analog Input Device

User's Guide

Trademark and Copyright Information

Measurement Computing Corporation, InstaCal, Universal Library, and the Measurement Computing logo are either trademarks or registered trademarks of Measurement Computing Corporation. Refer to the Copyrights & Trademarks section on Digilent.com for more information about trademarks. Other product and company names mentioned herein are trademarks or trade names of their respective companies.

© 2025 Digilent. All rights reserved. No part of this publication may be reproduced, stored in a retrieval system, or transmitted, in any form by any means, electronic, mechanical, by photocopying, recording, or otherwise without the prior written permission of Digilent.

Notice

Digilent does not authorize any Measurement Computing Corporation product for use in life support systems and/or devices without prior written consent from Digilent. Life support devices/systems are devices or systems that, a) are intended for surgical implantation into the body, or b) support or sustain life and whose failure to perform can be reasonably expected to result in injury. Measurement Computing Corporation products are not designed with the components required, and are not subject to the testing required to ensure a level of reliability suitable for the treatment and diagnosis of people.

Table of Contents

Preface	
About this User's Guide	5
What you will learn from this user's guide	5
Conventions in this user's guide	5
Where to find more information	5
Hazardous voltages.....	5
Hazardous locations.....	5
Chapter 1	
Introducing the USB-2404-UI	6
Overview: USB-2404-UI features	6
Functional block diagram	7
Chapter 2	
Installing the USB-2404-UI	8
What comes with your USB-2404-UI shipment?	8
Hardware	8
Unpacking.....	8
Installing the software	8
Installing the hardware	8
Calibrating the USB-2404-UI.....	9
Chapter 3	
Functional Details	10
Components.....	10
Spring terminal connectors	10
Strain relief slot.....	111
USB connector.....	111
LED	111
Connecting wires to the spring terminals	111
TEDS sensor connections	122
Signal source connections.....	122
Timing options.....	12
USB-2404-UI circuitry	13
Analog input circuitry	13
Voltage and current modes	13
4-wire resistance and 4-wire RTD modes	13
3-wire RTD mode	14
2-wire resistance and quarter-bridge modes.....	14
Half-bridge and full-bridge modes.....	14
Thermocouple mode	15
Excitation protection.....	15
Chapter 4	
Specifications	16
Analog input	16
Input mode ranges.....	17
Accuracy	17
Stability.....	18
Input noise	18
Excitation level	18
Power.....	19
Bus interface.....	19
Environmental	19

Mechanical19
Spring terminal connectors19

About this User's Guide

What you will learn from this user's guide

This user's guide describes the Measurement Computing USB-2404-UI data acquisition device and lists device specifications.

Conventions in this user's guide

For more information about ...

Text presented in a box signifies additional information and helpful hints related to the subject matter you are reading.

Caution! Shaded caution statements present information to help you avoid injuring yourself and others, damaging your hardware, or losing your data.

bold text **Bold** text is used for the names of objects on a screen, such as buttons, text boxes, and check boxes.

italic text *Italic* text is used for the names of manuals and help topic titles, and to emphasize a word or phrase.

Where to find more information

Additional information about USB-2404-UI hardware is available on our website at www.digilent.com. You can also contact Digilent with specific questions.

- Forum: <https://forum.digilent.com/forum/39-data-acquisition-daq-data-logging/>

For international customers, contact your local distributor. Refer to the Distributors section on our website at www.digilent.com/shop/distributors.

Hazardous voltages

The USB-2404-UI is not certified for use with hazardous voltages. You can connect voltages up to 30 VAC or 60 VDC to earth ground.

Hazardous locations

The USB-2404-UI is not certified for use in hazardous locations.

Introducing the USB-2404-UI

Overview: USB-2404-UI features

This user's guide contains all the information you need to connect the USB-2404-UI to your computer and to the signals you want to measure.

The USB-2404-UI is a USB 2.0 high-speed device that is supported under Microsoft® Windows® operating systems. The USB-2404-UI is fully compatible with both USB 1.1 and USB 2.0 ports.

The USB-2404-UI provides four channels of 24-bit universal analog input with integrated signal conditioning. The device can be used to measure several signals from sensors such as RTDs, thermocouples, load cells, and other powered sensors. The four channels are individually configurable, so a different measurement type can be performed on each channel. All channels are measured simultaneously at up to 100 S/s per channel.

The USB-2404-UI can perform the following measurements:

- Voltage
- Current
- Thermocouple
- RTD (4-wire and 3-wire)
- Resistance (4-wire and 2-wire)
- Bridge-based sensors (quarter-, half-, and full-bridge)

Measurement ranges vary for each type of measurement.

The device features built-in current and voltage excitation. The excitation circuit is protected from overcurrent and overvoltage fault conditions. Each channel also has a built-in thermistor for cold-junction compensation (CJC) calculations when measuring thermocouples.

An analog pre-filter removes noise that may be present in the signals prior to conversion. With channel-to-channel and channel-to-ground functional isolation, the USB-2404-UI protects the individual channels from noise caused by ground spikes and ensures a reliable data stream. An on-board LED indicates the status of the device.

Each channel has a detachable six-position spring terminal for field wiring connections.

The USB 2.0 high-speed driver transfers data at rates up to 480 Mbps. The USB-2404-UI is powered by the +5 volt USB supply from your computer. No external power is required.

Functional block diagram

USB-2404-UI functions are illustrated in the block diagram shown here.

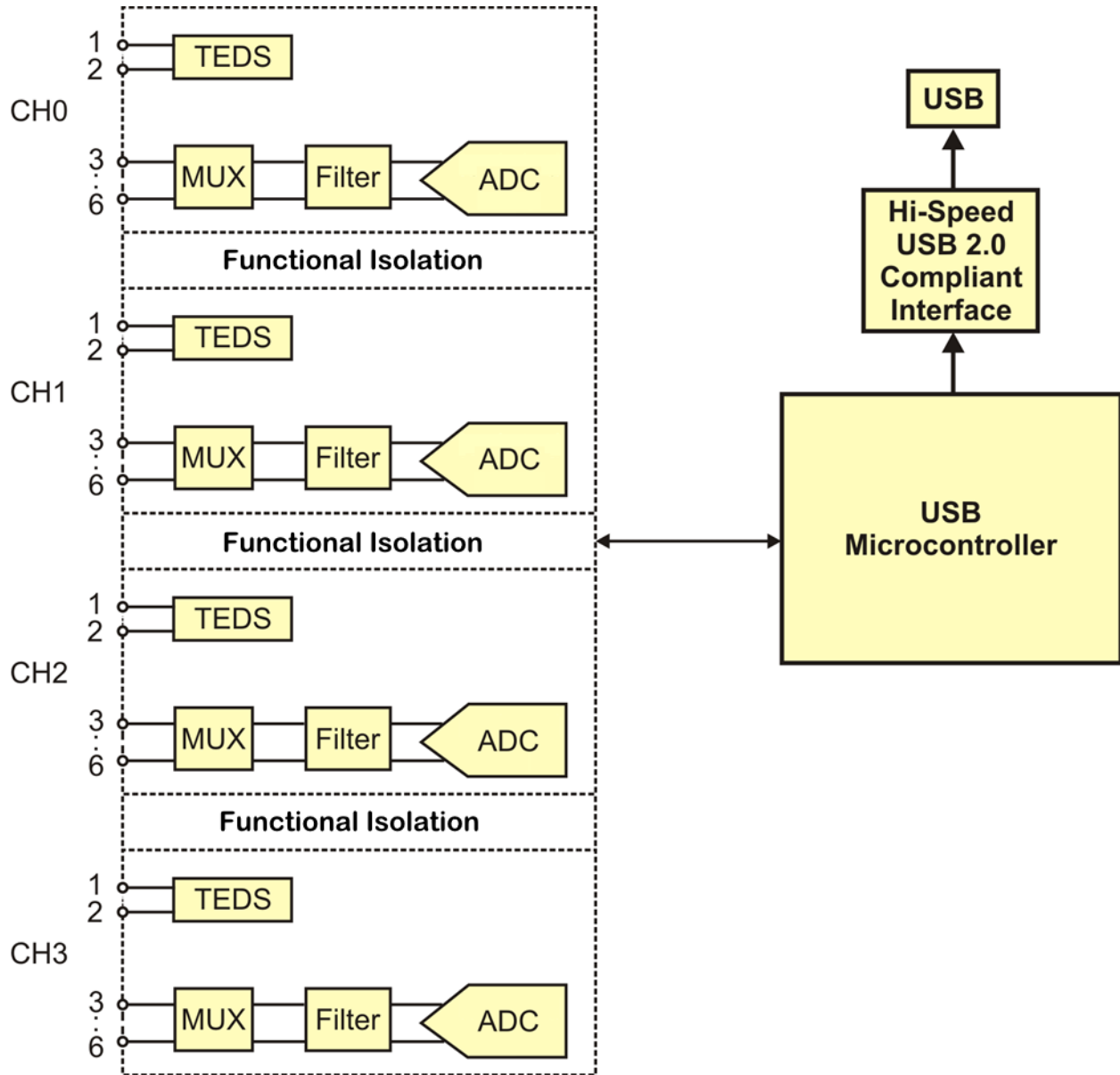

Figure 1. USB-2404-UI block diagram

Installing the USB-2404-UI

What comes with your USB-2404-UI shipment?

As you unpack your USB-2404-UI, verify that the following components are included.

Hardware

- USB-2404-UI
- USB cable (2 meter length)
- Four 6-position spring terminal connector blocks

Unpacking

As with any electronic device, you should take care while handling to avoid damage from static electricity. Before removing the USB-2404-UI from its packaging, ground yourself using a wrist strap or by simply touching the computer chassis or other grounded object to eliminate any stored static charge.

If your USB-2404-UI is damaged, notify Digilent immediately via the www.digilent.com or the forum.

- Forum: <https://forum.digilent.com/forum/39-data-acquisition-daq-data-logging/>

For international customers, contact your local distributor. Refer to the Distributors section on our website at www.digilent.com/shop/distributors.

Installing the software

Refer to the *MCC DAQ Software Quick Start* for instructions on installing the software: <https://digilent.com/reference/daq-and-datalogging/documents/mcc-daq-sw-quick-start>.

The software installation includes InstaCal and the Universal Library, to develop data acquisition applications using Windows programming languages.

Installing the hardware

Install the software before you install your device

A driver needed to run the USB-2404-UI device is installed when you install the software. Therefore, you need to install the software package you plan to use before you install the hardware.

For operation on a Windows operating system, we recommend that you run Windows Update to update your operating system with the latest USB drivers.

Be sure you are using the latest system software

Before you install your USB-2404-UI, run Windows Update to update your operating system with the latest USB drivers.

To connect the USB-2404-UI to your system, turn your computer on, and connect the USB cable to a USB port on your computer or to an external USB hub that is connected to your computer. The USB cable provides power and communication to the USB-2404-UI.

USB 2.0 port or hub recommended

For optimum performance, connect the USB-2404-UI to a USB 2.0 Hi-Speed host controller (480 Mbps) and USB 2.0 high-speed hub. The USB-2404-UI can be connected to a USB 1.1 Full-Speed port or hub, although performance may be affected.

To connect a USB-2404-UI device to your system, turn on your computer and connect the USB cable to an available USB port on the computer or to an external USB hub connected to the computer. Connect the other end of the USB cable to the USB connector on the device. No external power is required.

When you connect the device for the first time to a computer running Windows, a **Found New Hardware** dialog opens when the operating system detects the device. The dialog closes after the device is installed.

The green LED on the USB-2404-UI blinks steadily to indicate that the device is initialized and receiving power.

Allow the USB-2404-UI to operate for at least 30 minutes before using the device. This warm up time is required to achieve the specified rated accuracy of measurements.

Caution! Do not disconnect any device from the USB bus while the computer is communicating with the USB-2404-UI, or you may lose data and/or your ability to communicate with the device.

If the LED is off

If the LED is on but then turns off, the computer has lost communication with the USB-2404-UI device. To restore communication, disconnect the USB cable from the computer and then reconnect it. This should restore communication, and the LED should turn on.

Calibrating the USB-2404-UI

The USB-2404-UI is shipped fully calibrated. Calibration coefficients are stored in EEPROM. The normal calibration interval is once per year. Contact Digilent to inquire about recalibration.

Functional Details

Components

The USB-2404-UI has the following external components:

- Spring terminal connectors
- Strain relief slot for USB cable
- USB connector
- LED

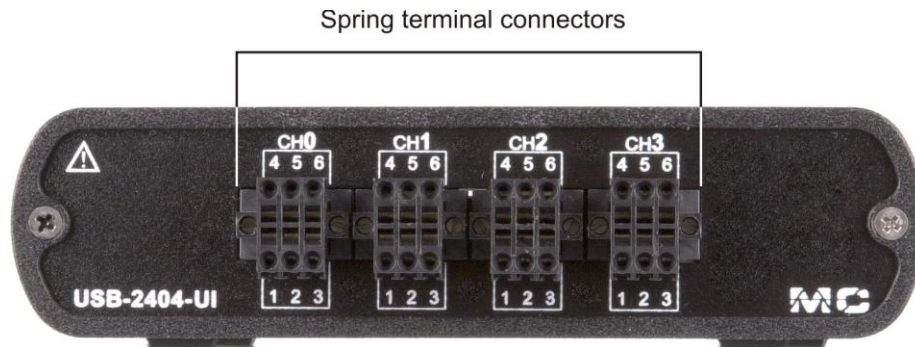

Figure 2. Front panel

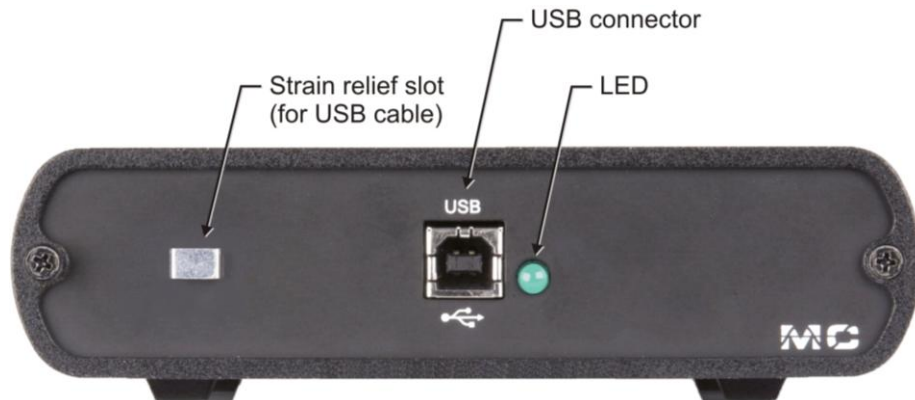

Figure 3. Rear panel

Spring terminal connectors

The USB-2404-UI has four 6-terminal connectors (CH0 to CH3) that provide connections for four analog input channels. The signal names for the spring terminal in each connector are listed in the table below.

6-terminal connector signal names

Terminal number	Signal name	Signal description
1	T+	TEDS Data
2	T-	TEDS Common
3*	EX+/HI	Positive excitation or input signal
4	HI	Positive input signal
5*	EX-/LO	Negative excitation or input signal
6	LO	Negative input signal

* Depending on the input mode, terminals 3 and 5 are either excitation signals or input signals.

- Connect the positive signal of the signal source to the positive input signal terminal (**HI**).
- Connect the negative signal of the signal source to the negative input signal terminal (**LO**).
- Connect to the excitation terminals (**EX+ / EX-**)-if the sensor requires a separate excitation connection.

The spring terminal assignments for each input mode are listed in the following table.

6-position spring terminal assignments per input mode

Terminal	Voltage TC	Current	Bridge			Resistance		RTD	
			Full	Half	Quarter	2-wire	4-wire	4-wire	3-wire
3	—	HI	EX+	EX+	HI		EX+	EX+	
4	HI	—	HI	HI	—		HI	—	
5	LO	LO	EX-	EX-	LO		EX-	EX-	
6	—	—	LO	LO	—		LO	LO	

Refer to "USB-2404-UI circuitry" on page 13 for information about connections in each mode.

Strain relief slot

Use the strain relief slot to keep the USB cable from disconnecting from the device inadvertently. Feed a tie wrap through the slot and secure to the USB cable when it is connected to the device.

USB connector

The USB connector provides +5 V power and communication. The voltage supplied through the USB connector is system-dependent, and may be less than 5 V. No external power supply is required.

LED

The LED indicates the device status. When connected to a USB port, the LED blinks steadily to indicate that the device is initialized and receiving power. Refer to the following table for the possible LED states.

LED state/device status

LED state	Device status
Not lit	The device is not connected to a USB port or hub.
Continuous single-blink	The device is operating normally.
Continuous double-blink	The device is operating normally. (Connected to a USB 1.1 port or hub.)

Connecting wires to the spring terminals

Use a flathead screwdriver with a blade smaller than 2.3 x 1.0 mm (0.09 x 0.04 in.) to connect wires to the detachable spring terminal connectors. Use 18 to 28 AWG copper conductor wire with 7 mm (0.28 in.) of insulation stripped from the end when wiring connections.

Insert the screwdriver into the spring clamp activation slot and press a wire into the corresponding connector terminal, then remove the screwdriver to clamp the wire into the terminal.

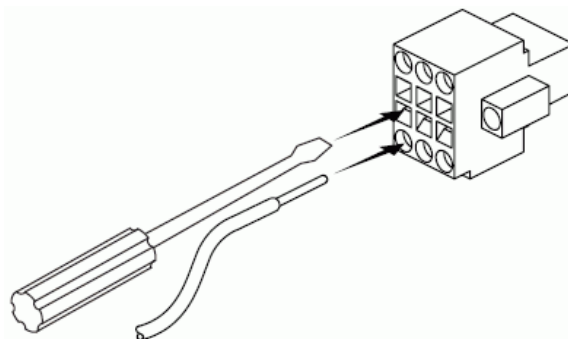

Figure 4. Connecting a wire to the spring terminal connector

TEDS sensor connections

The USB-2404-UI supports class II TEDS "smart" sensors only. Connect the two TEDS lines to **TEDS Data** (T+) and **TEDS Common** (T-), and ensure that neither T+ nor T- is tied in common to any of the signal inputs (terminals 3 through 6).

Signal source connections

You can connect ground-referenced or floating signal sources to the USB-2404-UI. For optimum signal quality, use shielded cables and twisted pair wiring whenever possible.

When making a floating connection between the signal source and the USB-2404-UI, make sure the voltages on the positive and negative connections are within the channel-to-earth voltage range. Refer to the *Specifications* chapter for operating voltages and information about overvoltage protection.

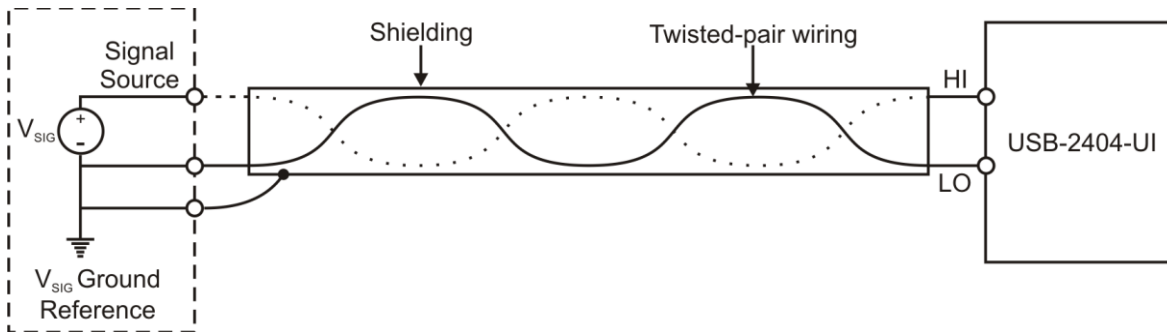

Figure 5. Connecting a grounded signal source

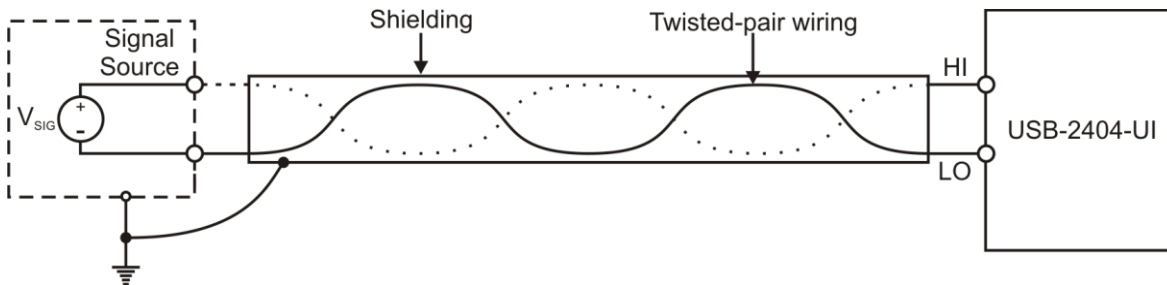

Figure 6. Connecting a floating signal source

Timing options

The USB-2404-UI supports four timing options. Each option is optimized for different types of applications by using different ADC conversion times.

- **High Speed:** optimized for high-speed applications at the expense of noise rejection.
- **Best 60 Hz Rejection:** optimized for rejection of 60 Hz noise.
- **Best 50 Hz Rejection:** optimized for rejection of 50 Hz noise.
- **High Resolution:** optimized for maximum overall noise rejection, and provides a good rejection of both 50 Hz and 60 Hz noise.

Refer to the analog input specifications for the conversion time and rejection ratio of each option.

USB-2404-UI circuitry

Analog input circuitry

The USB-2404-UI is channel-to-channel functionally isolated. Four 24-bit analog-to-digital converters (ADCs) simultaneously sample all four analog input channels. An excitation circuit is enabled for all input modes that require excitation. The ADC and excitation circuits are reconfigured in each mode to accommodate each sensor type. Figure 7 shows the input circuitry for one channel.

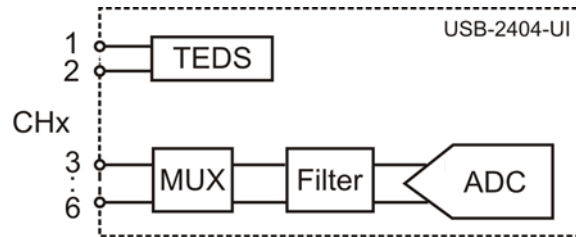

Figure 7. Input circuitry for one channel

Voltage and current modes

In voltage and current modes, connect the signal source to the USB-2404-UI across the HI and LO terminals. The current is computed from the voltage that the ADC measures across an internal shunt resistor. Voltage and current mode connections are shown in Figure 8.

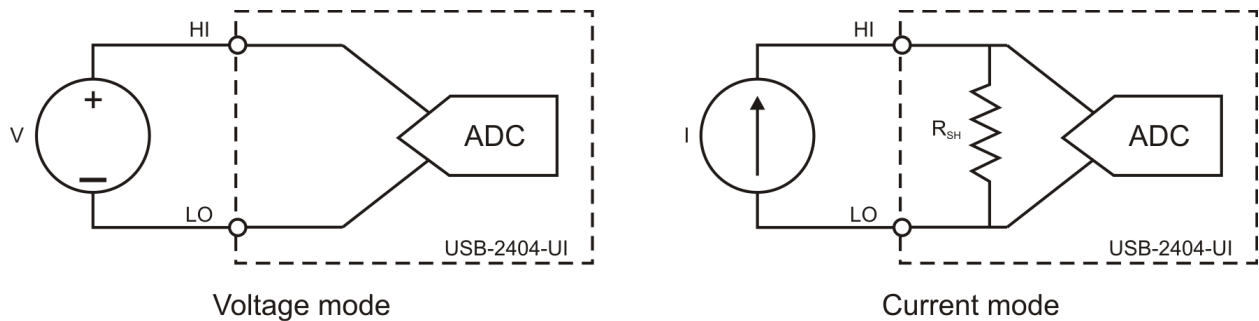

Figure 8. Voltage and current mode connections

4-wire resistance and 4-wire RTD modes

4-wire resistance and 4-wire RTD modes source a current which varies based on the resistance of the load between the EX+ and EX- terminals. The measured resistance is calculated from the resulting voltage reading.

These modes are not affected by lead wire resistance, because a negligible amount of current flows across the HI and LO terminals due to the high impedance of the ADC. 4-wire resistance and 4-wire RTD mode connections are shown in Figure 9.

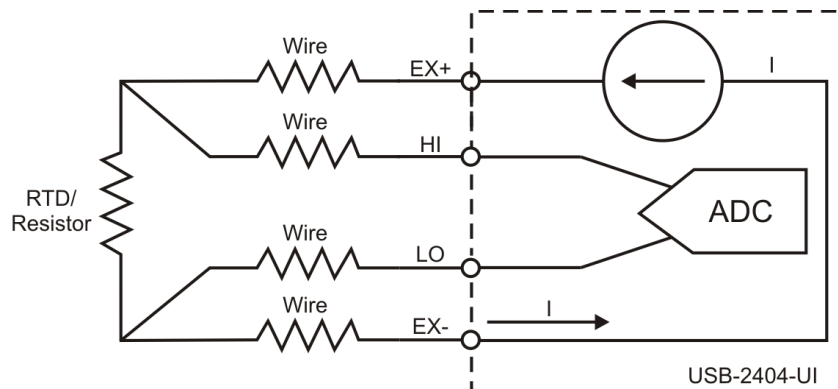

Figure 9. 4-wire resistance and 4-wire RTD mode connections

3-wire RTD mode

3-wire RTD mode sources a current which varies based on the resistance of the load between the EX+ and EX- terminals. This mode compensates for lead wire resistance in hardware if all lead wires have the same resistance. A gain of 2x is applied to the voltage across the negative lead wire. The ADC uses this voltage as the negative reference to cancel the resistance error across the positive lead wire. 3-wire RTD mode connections are shown in Figure 10.

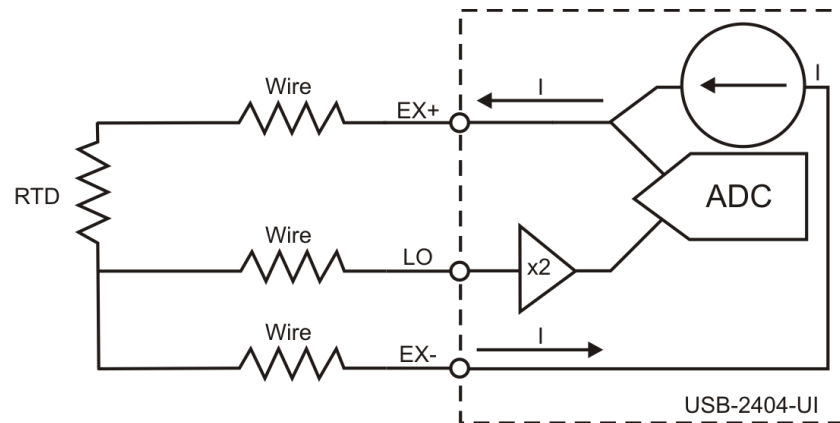

Figure 10. 3-wire RTD mode connections

2-wire resistance and quarter-bridge modes

In 2-wire resistance and quarter-bridge modes, connect the two ends of the resistor or gauge to the USB-2404-UI across the HI and LO terminals. These modes source a current which varies based on the resistance of the load between the HI and LO terminals. The resulting resistance is calculated from the voltage measurement. 2-wire and quarter-bridge modes do not compensate for lead wire resistance. 2-wire resistance and quarter-bridge mode connections are shown in Figure 11.

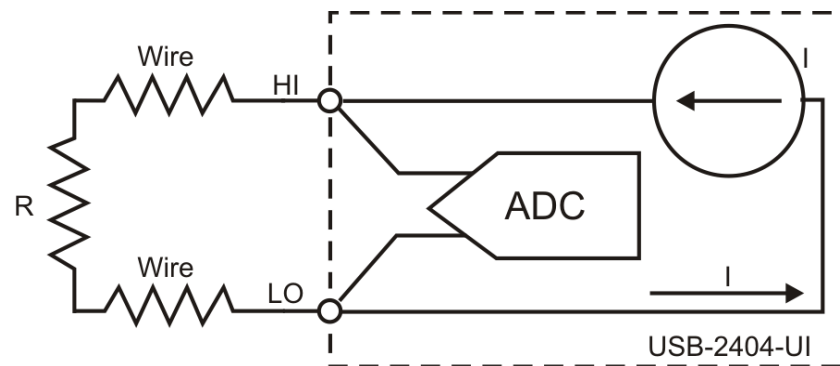

Figure 11. 2-wire resistance and quarter-bridge mode connections

Half-bridge and full-bridge modes

Half-bridge and full-bridge modes use the internal voltage excitation to set the input range of the ADC, and return voltage readings that are proportional to the excitation level. The internal excitation voltage is nominally 2.5 V, but it can vary based on the resistance of the sensor. Refer to the *Specifications* chapter for more information about excitation levels.

In half-bridge mode, the HI input is referenced to EX-. In full-bridge mode, the ADC reads the HI and LO inputs differentially.

Half-bridge and full-bridge mode connections are shown in Figure 12. The dotted lines in the figure represent the portion of the circuit that is only connected in full-bridge mode.

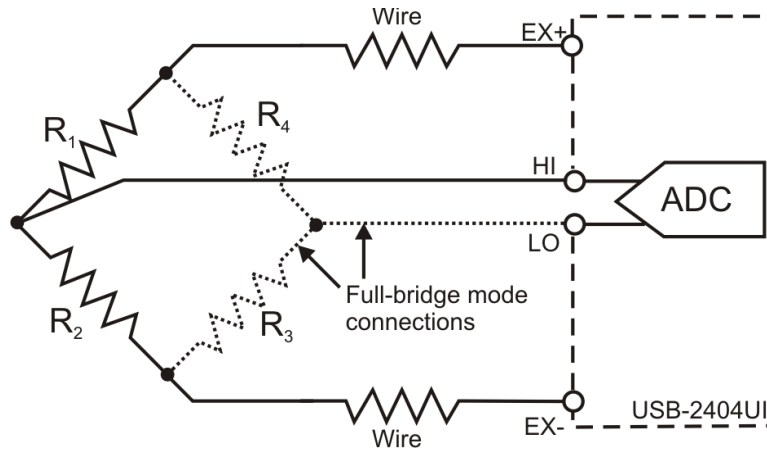

Figure 12. Half-bridge and full-bridge mode connections

Thermocouple mode

In thermocouple mode, connect the positive end of the thermocouple to HI, and the negative end of the thermocouple to LO. This mode uses the ± 1.25 mV range of the ADC to return a voltage reading. Use shielded cables and twisted pair wiring, and ground the shielded cables.

Each channel has a built-in thermistor for cold-junction compensation (CJC) calculations. For improved CJC sensor accuracy, operate the USB-2404-UI in a stable temperature environment, and avoid placing heat sources near the device or its connectors. Open thermocouple detection is not supported. Refer to the *Specifications* chapter for more information about accuracy. Thermocouple mode connections are shown in Figure 13.

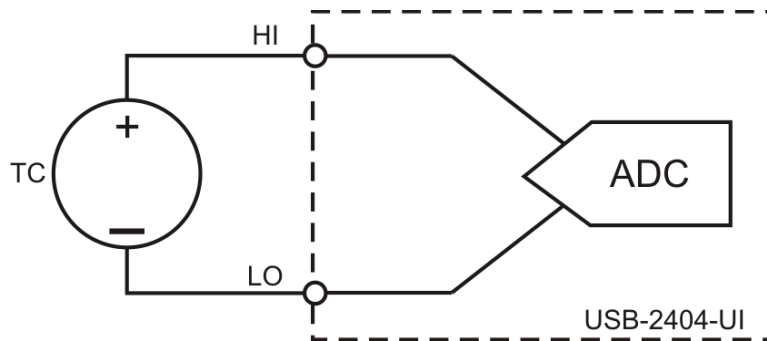

Figure 13. Thermocouple mode connections

Excitation protection

The USB-2404-UI excitation circuit is protected from overcurrent and overvoltage fault conditions. The circuit is automatically disabled in the event of a fault condition. Whenever possible, channels automatically recover after the fault is removed.

Specifications

All specifications are subject to change without notice.
Typical for the range 0 to 60 °C unless otherwise noted.

Analog input

Table 1. Analog input specifications

Parameter	Conditions	Specification
Number of channels		4
A/D converter resolution		24-bit
A/D converter type		Delta-Sigma with analog pre-filtering
Sampling mode		Simultaneous
TEDS sensor type supported		IEEE 1451.4 TEDS Class II (interface)
Input mode		<ul style="list-style-type: none"> ▪ Voltage ▪ Current ▪ Resistance (4-wire and 2-wire) ▪ RTD (3-wire and 4-wire) ▪ Thermocouple ▪ Quarter-bridge ▪ Half-bridge ▪ Full-bridge
Conversion time (No channels in TC mode)	High speed	10 ms for all channels
	Best 60 Hz rejection	110 ms for all channels
	Best 50 Hz rejection	130 ms for all channels
	High resolution	500 ms for all channels
Conversion time (One or more channels in TC mode)	High speed	20 ms for all channels
	Best 60 Hz rejection	120 ms for all channels
	Best 50 Hz rejection	140 ms for all channels
	High resolution	510 ms for all channels
Overvoltage protection	Terminals 1 and 2	±30 V
	Terminals 3 through 6, across any combination	±60 V
Input impedance	Voltage mode (±60 V, ±15 V, ±4 V)	1 MΩ
	Current mode	<40 Ω
	All other modes	>1 GΩ
Input bias current		<1 nA
Integral non-linearity (INL)		±15 ppm
Common mode rejection ratio (CMRR)	$f_{in} = 60$ Hz	>100 dB
Normal mode rejection ratio (NMRR)	Best 60 Hz rejection	90 dB at 60 Hz
	Best 50 Hz rejection	80 dB at 50 Hz
	High resolution	65 dB at 50 Hz and 60 Hz

Input mode ranges

Table 2. Input mode range specifications

Input mode	Nominal range(s)	Actual range(s)
Voltage	± 60 V, ± 15 V, ± 4 V, ± 1 V, ± 125 mV	± 60 V, ± 15 V, ± 4 V, ± 1 V, ± 125 mV
Current	± 25 mA	± 25 mA
4-wire and 2-wire resistance	10 k Ω , 1 k Ω	10.5 k Ω , 1.05 k Ω
Thermocouple	± 125 mV	± 125 mV
4-wire and 3-wire RTD	Pt 1000, Pt 100	5.05 k Ω , 505 Ω
Quarter-bridge	350 Ω , 120 Ω	390 Ω , 150 Ω
Half-bridge	± 500 mV/V	± 500 mV/V
Full-bridge	± 62.5 mV/V, ± 7.8 mV/V	± 62.5 mV/V, ± 7.8125 mV/V

Accuracy

Table 3. Accuracy specifications

Mode, range	Gain error (percent of reading)	Offset error (ppm of range)
	Typical 25 °C, ± 5 °C, -40 to 70 °C maximum	
Voltage, ± 60 V	± 0.3 , ± 0.4	± 20 , ± 50
Voltage, ± 15 V	± 0.3 , ± 0.4	± 60 , ± 180
Voltage, ± 4 V	± 0.3 , ± 0.4	± 240 , ± 720
Voltage, ± 1 V	± 0.1 , ± 0.18	± 15 , ± 45
Voltage/Thermocouple, ± 125 mV	± 0.1 , ± 0.18	± 120 , ± 360
Current, ± 25 mA	± 0.1 , ± 0.6	± 30 , ± 100
4-wire and 2-wire (note 1) resistance, 10 k Ω	± 0.1 , ± 0.5	± 120 , ± 320
4-wire and 2-wire (note 1) resistance, 1 k Ω	± 0.1 , ± 0.5	± 1200 , ± 3200
4-wire and 3-wire RTD, Pt 1000	± 0.1 , ± 0.5	± 240 , ± 640
4-wire and 3-wire RTD, Pt 100	± 0.1 , ± 0.5	± 2400 , ± 6400
Quarter-bridge, 350 Ω	± 0.1 , ± 0.5	± 2400 , ± 6400
Quarter-bridge, 120 Ω	± 0.1 , ± 0.5	± 2400 , ± 6400
Half-bridge, ± 500 mV/V	± 0.03 , ± 0.07	± 300 , ± 450
Full-bridge, ± 62.5 mV/V	± 0.03 , ± 0.08	± 300 , ± 1000
Full-bridge, ± 7.8 mV/V	± 0.03 , ± 0.08	± 2200 , ± 8000
Cold-junction compensation sensor accuracy		± 1 °C, typical

Note 1: 2-wire resistance mode accuracy depends on the lead wire resistance. This table assumes 0 Ω of lead wire resistance.

Stability

Table 4. Stability specifications

Measurement conditions	Gain drift (ppm of reading/ °C)	Offset drift (ppm of range/ °C)
Voltage, ±60 V	±20	±0.2
Voltage, ±15 V	±20	±0.8
Voltage, ±4 V	±20	±3.2
Voltage, ±1 V	±10	±0.2
Voltage/thermocouple, ±125 mV	±10	±1.6
Current, ±25 mA	±15	±0.4
4-wire and 2-wire resistance, 10 kΩ	±15	±3
4-wire and 2-wire resistance, 1 kΩ	±15	±30
4-wire and 3-wire RTD, Pt 1000	±15	±6
4-wire and 3-wire RTD, Pt 100	±15	±60
Quarter-bridge, 350 Ω	±15	±120
Quarter-bridge, 120 Ω	±15	±240
Half-bridge, ±500 mV/V	±3	±20
Full-bridge, ±62.5 mV/V	±3	±20
Full-bridge, ±7.8 mV/V	±3	±20

Input noise

Table 5. Input noise (ppm of rangersms) specifications

Mode, range	Conversion time			
	High speed	Best of 60 Hz rejection	Best of 50 Hz rejection	High resolution
Voltage, ±60 V	7.6	1.3	1.3	0.5
Voltage, ±15 V	10.8	1.9	1.9	0.7
Voltage, ±4 V	10.8	2.7	2.7	1.3
Voltage, ±1 V	7.6	1.3	1.3	0.5
Voltage/Thermocouple, ±125 mV	10.8	1.9	1.9	1.0
Current, ±25 mA	10.8	1.9	1.9	1.0
4-wire and 2-wire resistance, 10 kΩ	4.1	1.3	0.8	0.3
4-wire and 2-wire resistance, 1 kΩ	7.1	1.8	1.2	0.7
4-wire and 3-wire RTD, Pt 1000	7.6	1.7	1.1	0.4
4-wire and 3-wire RTD, Pt 100	10.8	1.9	1.9	0.9
Quarter-bridge, 350 Ω	5.4	1.0	1.0	0.7
Quarter-bridge, 120 Ω	5.4	1.0	1.0	0.7
Half-bridge, ±500 mV/V	3.8	0.5	0.5	0.2
Full-bridge, ±62.5 mV/V	5.4	1.0	1.0	0.8
Full-bridge, ±7.8 mV/V	30	4.7	4.7	2.3

Excitation level

Table 6. Half-bridge and full-bridge mode excitation level specifications

Measurement conditions	Load resistance (Ω)	Excitation (V)
Half-bridge	700	2.5
Half-bridge	240	2.0
Full-bridge	350	2.7
Full-bridge	120	2.2

Table 7. Resistance, RTD, and quarter-bridge mode excitation level specifications

Load resistance (Ω)	Excitation (mV)
120	50
350	150
1,000	430
10,000	2,200

Power

Table 8. Power specifications

Parameter	Specification
Current consumption from USB	500 mA, maximum

Bus interface

Table 9. Bus interface specifications

Parameter	Specification
USB specification	USB 2.0 Hi-Speed

Environmental

Table 10. Environmental specifications

Parameter	Specification
Operating temperature range	0 to 60 °C
Storage temperature range	-40 to 85 °C
Operating humidity	10 to 90% RH, non-condensing
Storage humidity	5 to 95% RH, non-condensing
Maximum altitude	2000 meter (6562 feet)

Note 2: The USB-2404-UI is intended for indoor use only, but may be used outdoors if installed in a suitable enclosure

Mechanical

Table 11. Mechanical specifications

Parameter	Specification
Dimensions	5.27" (L) x 5.64" (W) x 1.54" (H) (134 mm x 143 mm x 39 mm)
Weight	1.25 lbs (567 grams)

Isolation Voltages

Table 12. Isolation Voltages specifications

Parameter	Specification
Channel-to-earth ground isolation	Functional isolation
Channel-to-channel isolation	Functional isolation

Spring terminal connectors

Table 13. Spring terminal specifications

Connector type	Four 6-position spring terminal connectors (ACC-164)
Spring terminal wiring	18 to 28 AWG copper conductor wire with 7 mm (0.28 in.) of insulation stripped from the end.

Table 14. Signal names

Terminal number	Signal name	Signal description
1	T+	TEDS Data
2	T-	TEDS Common
3	EX+/HI (Note 4)	Positive excitation or input signal
4	HI	Positive input signal
5	EX-/LO (Note 4)	Negative excitation or input signal
6	LO	Negative input signal

Note 3: Depending on the input mode, terminals 3 and 5 are either excitation signals or input signals.

Table 15. Terminal assignments per input mode

Input mode	Signal terminals					
	1	2	3	4	5	6
Voltage	T+	T-	—	HI	LO	—
Current	T+	T-	HI	—	LO	—
4-wire resistance	T+	T-	EX+	HI	EX-	LO
2-wire resistance	T+	T-	HI	—	LO	—
Thermocouple	T+	T-	—	HI	LO	—
4-wire RTD	T+	T-	EX+	HI	EX-	LO
3-wire RTD	T+	T-	EX+	—	EX-	LO
Quarter-bridge	T+	T-	HI	—	LO	—
Half-bridge	T+	T-	EX+	HI	EX-	—
Full-bridge	T+	T-	EX+	HI	EX-	LO

Digilent c/o NI
11500 N. Mopac Expy.
Austin, Texas 78759
www.digilent.com/